

How to snap ground terminal blocks on to the mounting rail.

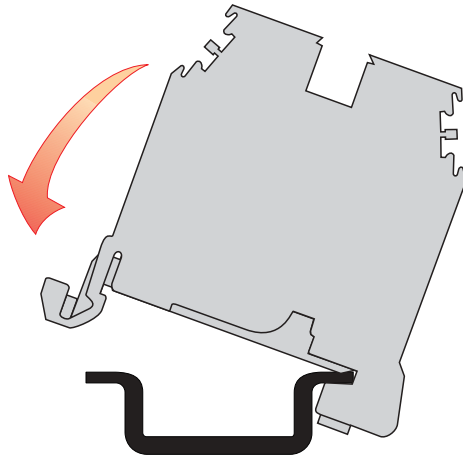

Snap the block on the mounting rail

One step process saves time and labor. Simply snap terminal block on rail. Bottom plate of block makes positive and secure contact with the rail. No additional screw tightening required. Center slot, at the top of the terminal block, provides access for easy jumpering of multiple blocks.

The snap-on terminal blocks cannot slide on the mounting rail. Sliding will damage the electrical connection.

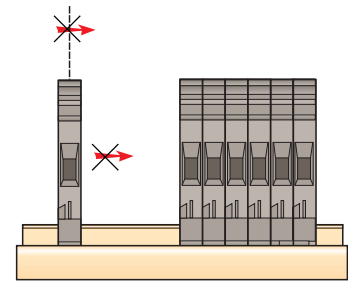

Ground terminal blocks electrically connected to the mounting rail

Compression clamp

DIN 3

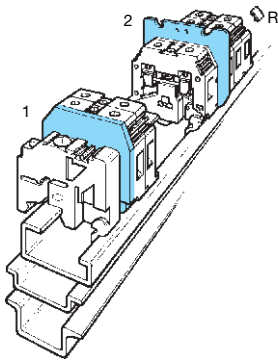

D 2,5/5.P

Spacing 5 mm - 0,08 .200"

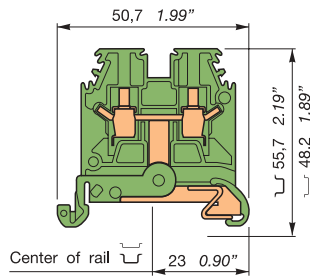

Mounting on rail by spring.

Type	Part number
Green body / yellow marking	
D 2,5/5.P	0165 909.05

IEC	UL	CSA
NFC DIN	24-12 AWG	24-12 AWG
Wire size	0,22-2,5 mm ²	24-12 AWG
Compression clamp	Stranded wire	
Short circuit current	300 A/1s	

Rated wire size / Gauge	Other characteristics
2,5 mm ² / A3	12 AWG
12 AWG	12 AWG
Wire stripping length	Recomm. screwdriver
10 mm .39"	3,5 mm .14"
	Recomm. torque
	0,4-0,6 Nm
	3,5-5,3 lb.in
	Protection

Approvals CE

Type	Part number
FEM6	th. 2.8 mm 0103 062.21
FEM6 V0	th. 2.8 mm 0199 305.02
SCF6	th. 3.0 mm 0118 707.03

On rail : Recomm.screwdriver/Recomm.torque
R See markers marking method (10) on the side, RC510 only on the top

D 4/6.P

Spacing 6 mm + 0,05 .238"

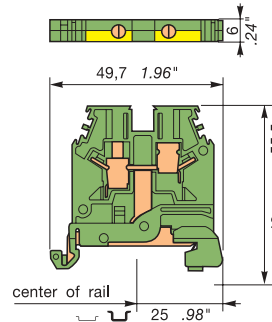

Type	Part number
Green-yellow	
D 4/6.P	0165 809.01
D 4/6.P.V0	0299 838.04

Terminal block for ground wire, same size as **M 4/6** terminal block.

IEC	UL	CSA
NFC-DIN	24-10 AWG	24-10 AWG
Wire size	0,22-4 mm ²	24-10 AWG
Compression clamp	Stranded wire	
Short circuit current	480A/1s	

Rated wire size / Gauge	Other characteristics
4 mm ² /A4	10 AWG
10 AWG	10 AWG
Wire stripping length	Recomm. screwdriver
9,5 mm .37"	4 mm .16"
	Recomm. torque
	0,5-0,8 Nm
	4,4-7 lb.in
	Protection

Approvals CE

Type	Part number
FEM6	th. 2,8 mm 0103 062.21
FEM6 V0	th. 2,8 mm 0199 305.02
SCF6	th. 3 mm 0118 707.03

On rail : Recomm.screwdriver/Recomm.torque
R See markers marking method (11) (12)

D 6/8.P

Spacing 8 mm - 0,05 .315"

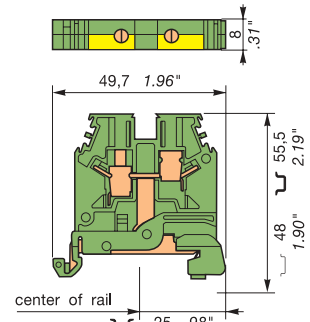

Type	Part number
Green-yellow	
D 6/8.P	0165 830.21
D 6/8.P.V0	0199 553.22

Terminal block for ground wire, same size as **M 6/8** terminal block.

IEC	UL	CSA
NFC-DIN	24-8 AWG	24-8 AWG
Wire size	0,22-6 mm ²	24-8 AWG
Compression clamp	Stranded wire	
Short circuit current	720A/1s	

Rated wire size / Gauge	Other characteristics
6 mm ² /A5	8 AWG
8 AWG	8 AWG
Wire stripping length	Recomm. screwdriver
12 mm .47"	4-5 mm .16" - .20"
	Recomm. torque
	0,8-1 Nm
	7,1-8,9 lb.in
	Protection

Approvals CE

Type	Part number
FEM6	th. 2,8 mm 0103 062.21
FEM6 V0	th. 2,8 mm 0199 305.02
SCF6	th. 3 mm 0118 707.03

On rail : Recomm.screwdriver/Recomm.torque
R See markers marking method (11) (12)